

SETTIMA MECCANICA

Pump your business



Screw pumps – series SMxT16B

Dry & submersible screw pumps for industrial applications

The people behind the Settima pumps

The Settima Meccanica adventure started in early 1978, with the ideas and the energy of an engineer, Mr. Cagnani, having the dream to produce reliable, high technology and low costs pumps, in order to set up an entrepreneurial activity able to create new jobs. The company started with one people and with the supply of a unique lift power unit manufacturer, leaded by one of the engineer's better friend. Believing in the potential of his people, in the technology innovation and research, the engineer walked trough the market, letting his team and his company grow. Now SETTIMA is the European leader in screw pumps for lift and elevator, having literally more than 500.000 of installation. In 2001 the company involved in the business more than 30 companies and overflowed the 30.000 pumps per year. The SETTIMA products are sold around the entire world and are the highest quality and cheaper on the market. The SETTIMA wealth is the employed team and all the people co-operating with them.

Settima screws pumps

The SETTIMA pumps are reliable, low noise and low cost; run without pulsation and guarantee a long life to your application.



Uses

The SETTIMA screws pumps coupled together with external or immersed motors run quietly and without pulsation. Are used in hydraulic application and systems of every kind.

Operation

The screws pumps of SETTIMA are positive displacement rotary pump with axial flow design. There are only three moving parts. The power rotor is the only driven part that extends outside the case. The idler screws actually act as sealing parts and are turned hydraulically by the fluid being pumped. There is only a rolling action between the drive screw and the idler ones. The rolling action eliminates noise and vibration.

Typical applications

- **Lube services** (diesel engines, turbines, compressors, gears & gear boxes)
- **Seal oil services** (compressors, generators)
- **Power Hydraulics** (presses, machine tools, working machines rolling mill, injection moulding machines, dumping equipment, elevators, variable pitch propellers, hydraulic winches)
- Various & **special applications** for industrial and marine uses
- **Food** (chocolate, syrups, vegetal oils)
- **Hydraulic governors**
- **Refinery & petrol chemical services**
- **Cooling**
- **Transfer services**
- **Fuel oil burners**

Detailed technical information

<i>Types</i>	Dry (SMT16B) or submersed (SMIT16B)
<i>Flanges</i>	ISO 3019/2 – IEC standard (for directed coupling with motor)
<i>Connections</i>	SAE 3000
<i>Installation position</i>	free for SMT 16B submerged (totally or partially) for SMIT 16B
<i>Drive loading</i>	No axial or radial loads
<i>Shaft rotation</i>	clockwise viewed at the shaft end
<i>Shaft speed</i>	From 500 to 3.600 rpm
<i>Model available</i>	20 – 32 – 40 – 45 – 55 – 60 – 70 – 80
<i>Flows</i>	From 8 up to 1.200 Lt/min (at 2.750 rpm)
<i>Outlet pressure</i>	40 bar continuous – 50 bar intermittent
<i>Inlet pressure</i>	Min. –0,7 / max. 3 bar
<i>Fluids</i>	mineral oil HLP e HLVP ecologic fluids HETG-HEPG-HEE synthetic fluid or emulsion: HFA oil-water emulsion - oil minimum 5% HFB water-oil emulsion \geq 40% HFC water/glycole – water max 35 to 55% HFDR phosphate ester Lubrication high viscosity oils (*) Special synthetic fluid : MIL-H, SKYDROL, special on request
<i>Viscosity</i>	from 4 up to 2.000 mm ² /s
<i>Seals</i>	NBR, VITON, FPM, EPDM – Special on request
<i>Noise</i>	from 52 up to 68 dB(A) at 2.750 rpm Value based on ISO 4412 test procedure
<i>Pump body (standard)</i>	extruded aluminium alloy
<i>Pump body (special application)</i>	cast iron, carbon steel
<i>Screw</i>	steel for primary screw , cast iron for secondary screw
<i>Environment temperature</i>	From -20° up to +60°C
<i>Hydraulic temperature</i>	From -20° up to +180°C
<i>Filtration</i>	permissible degree of fluid contamination NAS to 1638 class 10 or ISO DIS 4406 –19/16 Recommended filtration β 25 \geq 75
<i>Maintenance</i>	No

(*) For high viscosity applications and/or oil-air emulsions, please check with us the suitable pump model

The data shown in the catalogue can change without notice.
For special applications – please contact the main office.

Component description

Hollow shaft pump

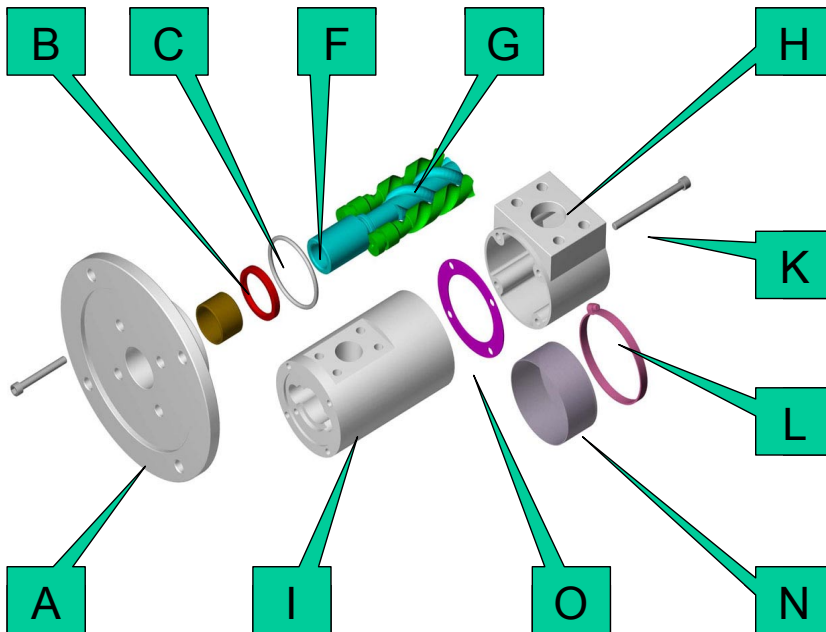

A	Mounting flange
B	Seals
C	O-ring seals
D	Seeger
E	Ball bearing (only for male shaft)
F	Main screw
G	Idler screw

Normal shaft pump

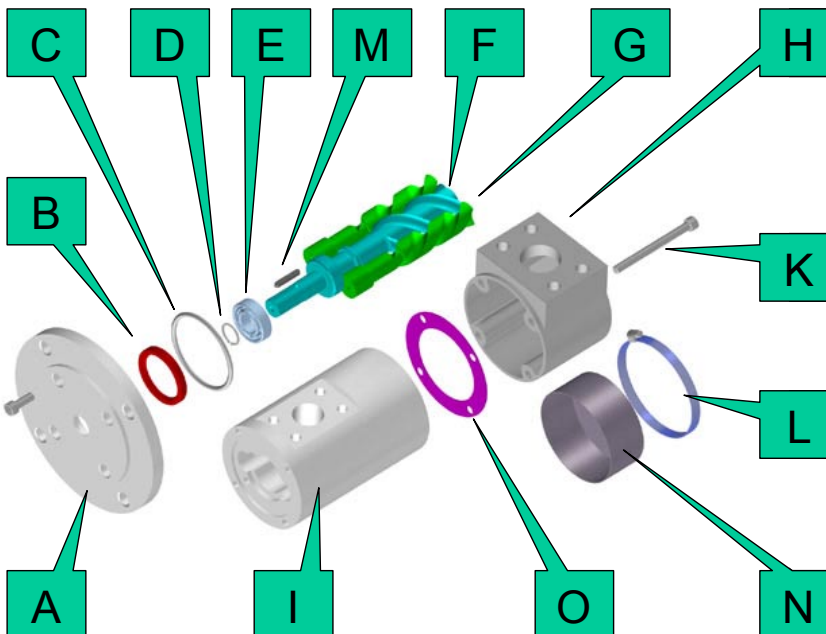

H	Suction cover (only for dry pump)
I	Body
K	TCEI screws
M	Key
N	Filter (only for submersible pump)
O	Plane gasket
L	Hose clamp

The data shown in the catalogue can change without notice.
For special applications – please contact the main office.

Dimensional drawing – series SMT16B

Dry screw pump

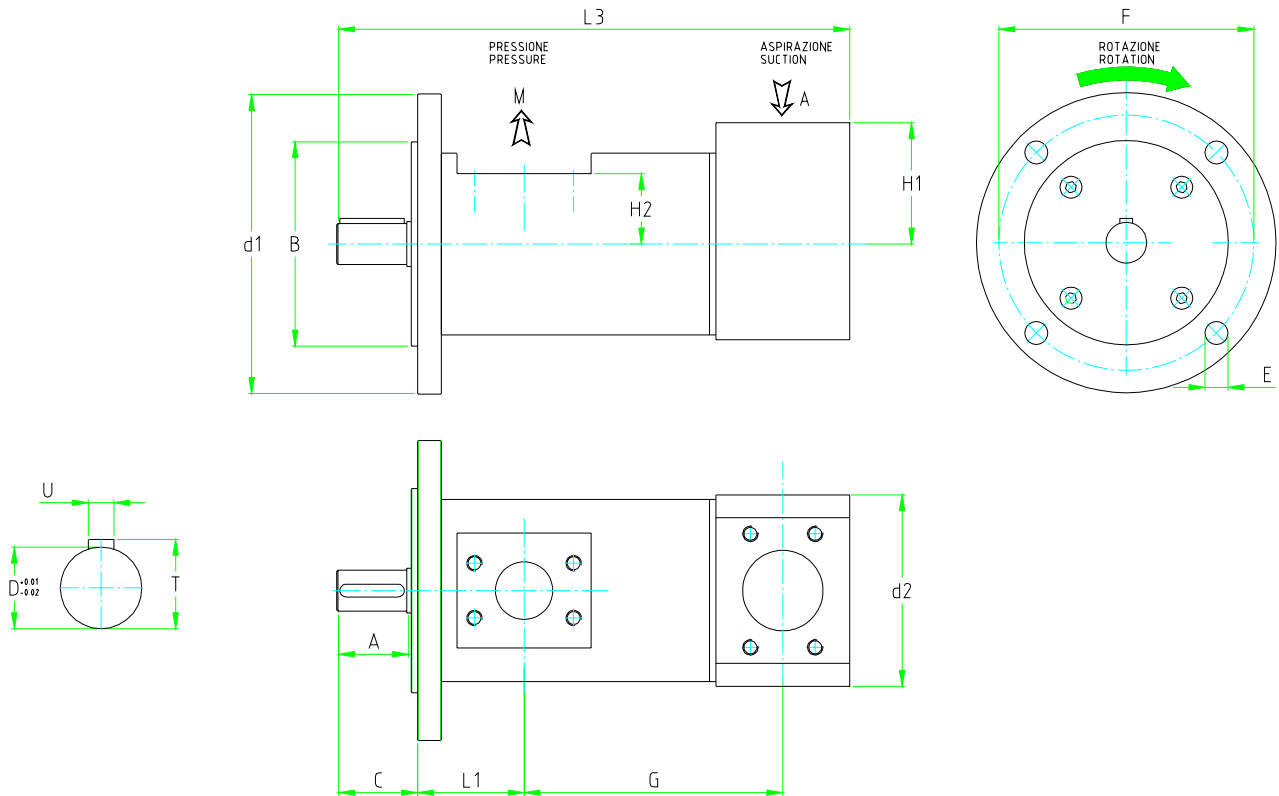

TIPO TYPE	Flange				Shaft				Suction		Discharge		Pump					
	B	E	F	d1	A	D	T	U	\varnothing_A	H1	\varnothing_M	H2	C	d2	L3	L1	G	Kg
GR 20 8-12-15-20L	80	11	103	125	31	14	16	5	1/2" GAS	25	3/4" GAS	25	37	59	187	55,5	76	1,5
GR25 (hollow shaft) 25-30L	70	6,5	85	105	-	14	16,2	5,2	3/4" GAS	26,7	1/2" GAS	27,3	-	65	174	70	86	2,7
GR 32 35-45-55-75L	100	11	125	150	36	19	21,5	6	1 1/4" SAE	54,5	1" SAE	41	41	95,5	259	62	122,5	4,4
GR 40 100-125-150L	125	14	160	188	36	19	21,5	6	1 1/2" SAE	65	1 1/4" SAE	46,5	46	112	304	69	150	7
GR 45 180-210L	125	14	160	188	55	32	35	10	2" SAE	83,5	1 1/2" SAE	51,5	64,5	126,5	375	75	190	11
GR 55 250-300-330-380L	160	18	200	235	55	32	35	10	2 1/2" SAE	94	2" SAE	54	64,5	148,5	398,5	83,5	202	15,5
GR 60 440-500L	160	18	200	235	55	32	35	10	3" SAE	105	2 1/2" SAE	63,5	66	160	440	83,5	228	25
GR 70 600-660-800L	200	22	250	300	55	32	35	10	3 1/2" SAE	110	3" SAE	83	67	181	506	93,5	277	30
GR 80 1000-1200L	200	22	250	300	60	38	41	10	4" SAE	125	3" SAE	83	76	212	594,5	150	295	47,5

The data shown in the catalogue can change without notice.
For special applications – please contact the main office.

Dimensional drawing – series SMIT16B

Submersible screw pump

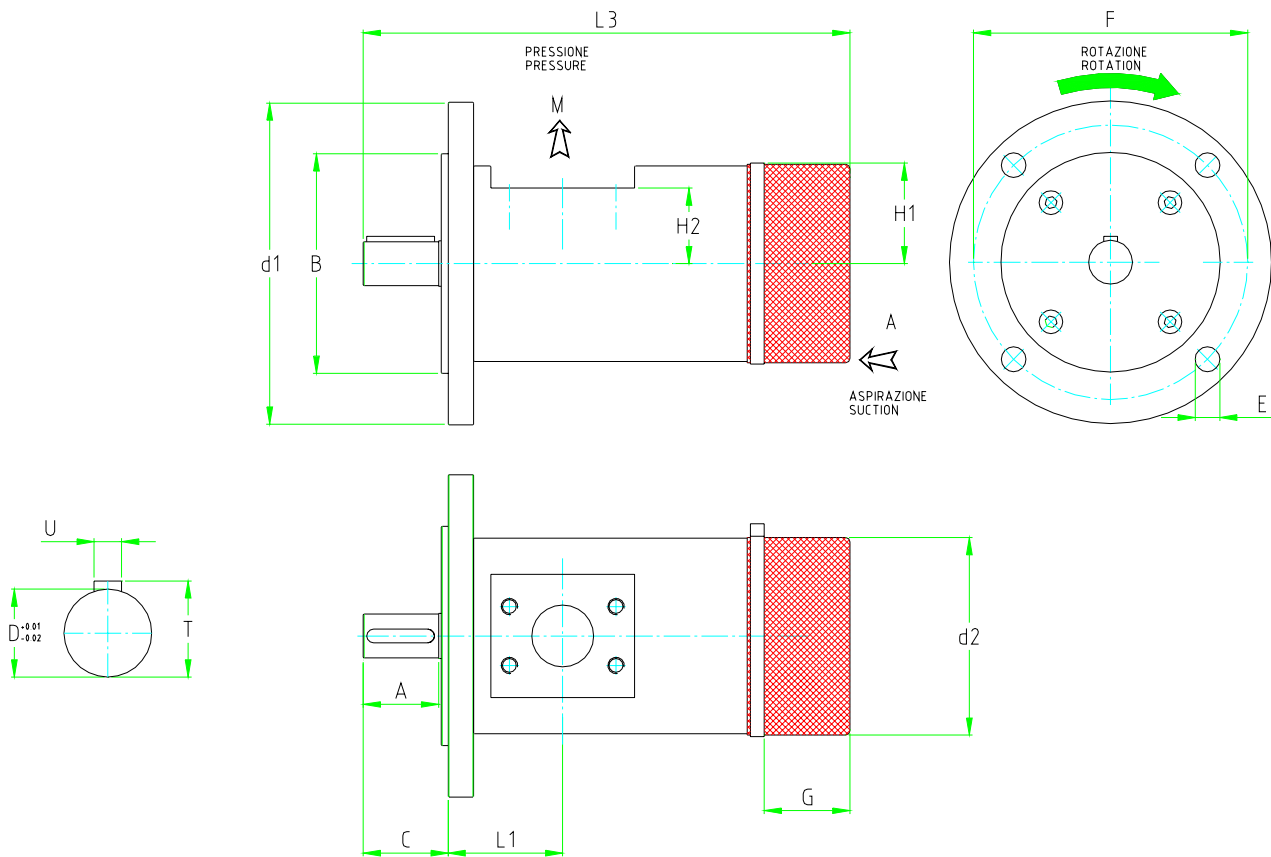

TIPO TYPE	Flange				Shaft				Discharge		Pump					Kg
	B	E	F	d1	A	D	T	U	\varnothing_M	H2	C	G	d2	L1	L3	
GR 20 8-12-15-20L	80	11	103	125	31	14	16	5	3/4" GAS	25	37	40	60	55,5	197	1,3
GR25 (hollow shaft) 25-30L	70	6,5	85	105	-	14	16,2	5,2	1/2" GAS	27,3	-	65	174	70	86	2,7
GR 32 35-45-55-75L	100	11	125	150	36	19	21,5	6	1" SAE	41	41	70	96	62	265	4
GR 40 100-125-150L	125	14	160	188	36	19	21,5	6	1 1/4" SAE	46,5	46	70	110	69	295	6,4
GR 45 180-210L	125	14	160	188	55	32	35	10	1 1/2" SAE	51,5	64,5	70	124	75	355	10
GR 55 250-300-330-380L	160	18	200	235	55	32	35	10	2" SAE	54	64,5	100	145	83,5	400	15
GR 60 440-500L	160	18	200	235	55	32	35	10	2 1/2" SAE	63,5	66	100	155	83,5	415	22
GR 70 600-660-800L	200	22	250	300	55	32	35	10	3" SAE	83	67	100	182	93,5	461	26
GR 80 1000-1200L	220	22	250	300	60	38	41	10	3" SAE	83	76	100	202	150	543	45

The data shown in the catalogue can change without notice.
For special applications – please contact the main office.

Direct coupling motor/pump

IEC standard motor

The flanges marked in the following table are available in stock.
For other couplings, please contact Settima Meccanica.
Special applications available.

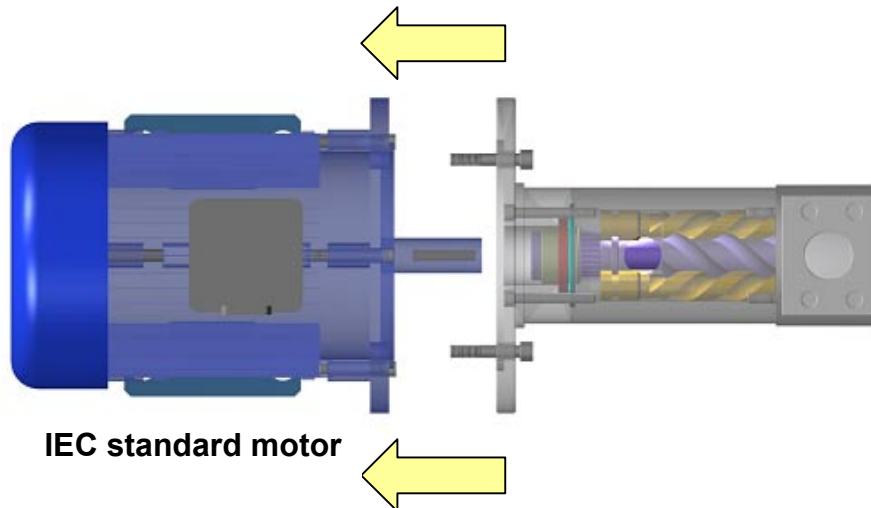

		Motor dimension								
Motor Form		56	63	71	80	90	100	112	132	160
GR20	B14									
	B5									
	B5 reduced									
GR25	B14									
	B5									
	B5 reduced									
GR32	B14									
	B5									
	B5 reduced									
GR40	B14									
	B5									
	B5 reduced									
GR45	B14									
	B5									
	B5 reduced									
GR55	B14									
	B5									
	B5 reduced									
GR60	B14									
	B5									
	B5 reduced									
GR70	B14									
	B5									
	B5 reduced									
GR80	B14									
	B5									
	B5 reduced									

Advantages:

- Save the costs for bell-housing and coupling
- Save time for mounting and maintenance
- Save the size

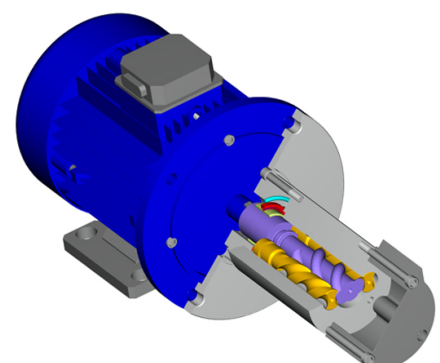

Performances

2 poles motor – 50Hz

Pump types SMT16B/SMIT16B – maximum operating pressure 40 bar
Flow / Pressure / Power tables

Type		6 cSt					68 cSt					400 cSt (*)					
		Operating pressure (bar)					Operating pressure (bar)					Operating pressure (bar)					
		5	10	20	30	40	5	10	20	30	40	5	10	20	30	40	
GR 20	8 L	l/min	8,3	8	7,2	-	-	9	8,8	8,6	8,3	8	9,6	9,3	9	8,6	8,3
		KW	0,2	0,2	0,3	-	-	0,2	0,2	0,4	0,6	0,7	0,2	0,3	0,5	0,7	0,9
	12 L	l/min	12,4	12,0	10,6	-	-	14,3	13,5	13,1	12,7	12,3	14,6	14,2	13,8	13,2	12,6
		KW	0,3	0,3	0,5	-	-	0,2	0,3	0,6	0,8	1,1	0,3	0,4	0,7	1	1,3
	15 L	l/min	16,0	15,6	14,0	-	-	18,5	17,5	17,0	16,5	16,0	18,6	18,3	18,0	17,4	17,0
		KW	0,4	0,4	0,6	-	-	0,3	0,4	0,6	1,1	1,4	0,3	0,5	0,9	1,4	1,8
23 L	l/min	23,0	22,7	21,0	-	-	26,3	25,2	24,6	24,0	23,5	26,6	26,3	26,0	25,2	24,8	
	KW	0,5	0,5	0,9	-	-	0,4	0,6	0,9	1,6	2	0,4	0,7	1,3	2	2,5	
GR25	25 L	l/min	27,7	26,8	23,7	-	-	31,9	30,1	29,2	28,3	27,5	32,6	31,7	30,8	29,5	28,1
		KW	0,7	0,7	1,1	-	-	0,4	0,7	1,3	1,8	2,5	0,7	0,9	1,6	2,2	2,9
30L	l/min	34,6	33,5	29,6	-	-	39,9	37,7	36,6	35,4	34,3	40,7	39,6	38,5	36,8	35,2	
	KW	0,8	0,8	1,4	-	-	0,6	0,8	1,7	2,2	3,1	0,8	1,1	2,0	2,8	3,6	
GR32	35 L	l/min	35,8	35,0	32,6	-	-	40,3	39,0	38,4	37,8	37,2	41,0	40,6	40,0	39,0	38,7
		KW	0,8	0,8	1,3	-	-	0,7	1,0	1,6	2,5	3,3	0,6	1	2	3	3,9
	45 L	l/min	45,2	44,0	40,6	-	-	49,3	48,8	48,4	48,0	47,5	51,3	50,8	50,3	49,2	48,8
		KW	0,8	1,0	1,6	-	-	0,8	1,2	2,2	3,2	4,0	0,7	1,3	2,5	3,8	4,8
	55 L	l/min	55,8	54,6	50,4	-	-	59,0	58,0	57,0	56,0	55,0	60,0	59,4	58,7	57,7	57,3
		KW	0,9	1,1	2	-	-	1,0	1,4	2,5	3,7	4,7	0,8	1,5	2,9	4,4	5,8
75 L	l/min	76,0	74,7	69,0	-	-	82,0	80,3	79,6	78,0	75,8	82,0	81,4	80,6	79,2	78,5	
	KW	1,0	1,6	2,8	-	-	1,2	1,8	3,3	4,7	6,0	1,2	2,1	4,1	6,0	8,0	
GR 40	100 L	l/min	98,4	97,0	90,5	-	-	106,0	104,0	100,0	96,0	92,8	107,0	106,0	105,0	103,0	102,4
		KW	1,2	2,0	3,6	-	-	1,5	2,5	4,5	6,5	8,4	1,5	2,7	5,3	7,8	10,0
	125 L	l/min	123,0	121,0	111,0	-	-	130,0	128,0	126,0	124,0	122,0	133,0	132,0	130,0	128,0	127,0
		KW	1,4	2,5	4,6	-	-	1,8	3,0	5,4	7,9	10,4	1,9	3,3	6,5	9,6	12,5
150 L	l/min	145,0	143,0	135,0	-	-	153,0	151,0	149,0	147,0	144,5	155,6	155,0	153,0	151,0	149,0	
	KW	1,6	3,0	5,6	-	-	2,0	3,5	6,5	9,5	12,8	2,2	3,9	7,7	11,4	15,0	
GR45	180 L	l/min	174,2	172,0	161,0	-	-	185,0	183,0	180,0	177,0	174,0	188,0	187,0	185,0	182,0	180,0
		KW	1,9	3,7	6,7	-	-	2,5	4,0	7,8	11,2	14,9	2,6	4,7	9,3	13,8	18,0
210 L	l/min	205	203,0	192,0	-	-	216,0	214,0	211,5	208,0	204,5	219,0	218,0	217,0	214,0	212,0	
	KW	2,4	4,2	8,0	-	-	3,0	5,0	9,0	13,4	17,3	3,0	5,5	10,9	16,2	21,0	
GR55	250 L	l/min	262,0	260,0	246,0	-	-	278,0	276,0	271,0	266,0	263,0	281,0	280,0	278,0	274,0	273,0
		KW	3,0	5,5	10,0	-	-	3,5	6,0	11,5	17,0	23,0	4,0	7,0	13,9	20,6	27,0
	300 L	l/min	293,8	291,0	276,0	-	-	308,0	305,0	301,0	297,0	293,0	311,6	310,0	308,0	304,0	302,0
		KW	3,6	6,2	11,0	-	-	4,0	6,9	12,5	18,8	24,0	4,6	7,8	15,4	23,0	30,0
330 L	l/min	334,0	330,0	315,0	-	-	352,0	346,0	340,0	334,0	330,0	354,0	352,0	349,0	343,0	341,0	
	KW	4,0	7,4	13,0	-	-	4,4	7,6	14,5	21,5	28,5	5,0	8,8	17,5	26,0	34,0	
380 L	l/min	373,0	370,0	356,3	-	-	389,0	386,5	382,0	378,0	374,0	396,0	394,4	391,0	387,1	383,0	
	KW	4,4	8,0	14,4	-	-	5,0	8,5	16,0	23,8	31,5	6,0	9,9	19,6	29,0	38,0	
GR 60	440 L	l/min	438,8	436,0	413,0	-	-	458,0	455,0	450,0	445,0	440,0	464,0	462,0	459,0	453,0	451,0
		KW	5,0	9,3	17,0	-	-	6,2	10,0	19,0	28,0	34,0	6,5	11,6	23,0	34,0	45,0
500 L	l/min	503,0	500,0	484,5	-	-	519,0	516,0	511,0	506,0	501,0	526,0	524,0	520,0	515,7	512,0	
	KW	6,2	11,0	19,0	-	-	7,5	11,0	22,0	30,0	42,0	7,4	13,2	26,0	38,0	51,0	
GR 70	600 L	l/min	609,0	606,0	580,0	-	-	628,0	625,0	619,0	614,0	608,0	635,0	633,0	629,0	622,0	620,0
		KW	7,4	13,0	24,0	-	-	8,0	14,0	26,0	38,0	51,0	9,0	16,0	31,5	46,0	62,0
	660 L	l/min	663,0	660,0	636,0	-	-	684,0	681,0	676,0	671,0	665,0	691,0	689,0	685,0	676,0	674,0
		KW	8,0	14,0	26,0	-	-	9,0	15,0	28,6	42,0	55,0	10,0	17,4	34,3	51,0	68,0
800 L	l/min	802	798,0	768,0	-	-	830,0	826,0	820,0	815,0	810,0	839,0	836,0	831,0	823,0	819,0	
	KW	9,0	16,7	31,0	-	-	10,5	18,0	34,0	51,0	68,0	11,0	21,0	42,0	62,0	82,0	
GR 80	1.000 L	l/min	1.000,0	996,0	972,0	-	-	1.034,0	1.030,0	1.024,0	1.017,0	1.010,0	1.043,0	1.040,0	1.035,0	1.026,0	1.023,0
		KW	11,0	20,5	40,0	-	-	12,5	22,0	43,0	64,0	85,0	15,0	26,0	52,0	76,0	103,0
1.200 L	l/min	1.218,0	1.214,0	1.170,0	-	-	1.254,0	1.250,0	1.242,0	1.234,0	1.225,0	1.268,0	1.264,0	1.258,0	1.247,0	1.241,0	
	KW	13,5	25,0	48,0	-	-	16,0	27,0	52,0	78,0	106,0	18,0	32,0	63,0	93,0	125,0	

(*) For high viscosity applications and/or oil-air emulsions, please check with us the suitable pump model

The data shown in the catalogue can change without notice.
For special applications – please contact the main office.

Performances

4 poles motor – 50Hz

Pump types SMT16B/SMIT16B – maximum operating pressure 40 bar
Flow / Pressure / Power tables

Type		6 cSt					68 cSt					400 cSt (*)					
		Operating pressure (bar)					Operating pressure (bar)					Operating pressure (bar)					
		5	10	20	30	40	5	10	20	30	40	5	10	20	30	40	
GR 20	8 L	l/min	3,7	3,6	3,0	-	-	4,2	4	3,9	3,7	3,5	4,5	4,4	4,3	4,2	4,1
		KW	0,2	0,2	0,2	-	-	0,2	0,2	0,2	0,3	0,4	0,2	0,2	0,3	0,4	0,5
	12 L	l/min	5,7	5,5	4,7	-	-	6,2	6,1	6,0	5,8	5,5	6,9	6,8	6,7	6,6	6,5
		KW	0,2	0,2	0,3	-	-	0,2	0,2	0,3	0,4	0,6	0,2	0,3	0,4	0,6	0,7
	15 L	l/min	7,3	7,0	5,9	-	-	8,2	8	7,8	7,4	7,0	8,9	8,8	8,7	8,5	8,2
		KW	0,2	0,2	0,3	-	-	0,2	0,2	0,4	0,6	0,8	0,2	0,3	0,5	0,7	0,9
23 L	l/min	10,8	10,4	8,9	-	-	11,8	11,5	11,2	10,8	10,3	12,8	12,7	12,5	12,2	11,8	
	KW	0,3	0,3	0,4	-	-	0,3	0,3	0,6	0,8	1,0	0,3	0,4	0,7	1,0	1,3	
GR25	25 L	l/min	12,7	12,3	10,5	-	-	13,8	13,6	13,4	12,9	12,3	15,4	15,2	15,0	14,7	14,5
		KW	0,4	0,4	0,7	-	-	0,4	0,4	0,7	0,9	1,3	0,4	0,6	0,9	1,3	1,6
30L	l/min	15,9	15,3	13,1	-	-	17,3	17,0	16,7	16,2	15,3	19,3	19,0	18,7	18,4	18,1	
	KW	0,6	0,6	0,8	-	-	0,6	0,6	0,8	1,1	1,7	0,6	0,7	1,1	1,7	2,0	
GR32	35 L	l/min	16,3	15,9	14,0	-	-	18,4	18,0	17,4	16,7	16,0	19,9	19,7	19,5	19,1	18,8
		KW	0,3	0,4	0,7	-	-	0,3	0,4	0,8	1,2	1,4	0,4	0,6	1	1,5	2,2
	45 L	l/min	20,5	20,0	17,8	-	-	22,8	22,5	22,0	21,2	20,5	25,0	24,8	24,4	23,9	23,4
		KW	0,3	0,5	0,8	-	-	0,4	0,5	1,0	1,4	1,8	0,5	0,8	1,3	1,9	2,4
	55 L	l/min	25,4	24,8	22,0	-	-	28,0	27,6	26,8	26,0	25,0	29,8	29,0	28,7	28,2	27,6
		KW	0,4	0,6	1,0	-	-	0,5	0,6	1,2	1,8	2,2	0,6	1,0	1,5	2,2	2,8
75 L	l/min	34,5	34,0	31,0	-	-	39,0	38,5	37,0	36,0	35,0	40,8	40,0	39,4	38,8	38,0	
	KW	0,4	0,7	1,4	-	-	0,6	0,8	1,6	2,3	2,9	0,7	1,2	2	3,0	3,9	
GR 40	100 L	l/min	48,1	44,5	39,0	-	-	50,2	49,8	48,0	46,7	45,2	52,7	52,0	51,3	50,2	49,0
		KW	0,6	1,0	1,7	-	-	0,8	1,0	2,0	3,0	3,8	0,8	1,4	2,6	3,8	5,0
	125 L	l/min	56,4	55,5	48,8	-	-	61,4	61,0	59,0	57,2	55,8	65,6	65,0	64,0	63,0	61,8
		KW	0,8	1,2	2,0	-	-	0,9	1,2	2,4	3,6	4,8	1	1,7	3,3	4,8	6,3
150 L	l/min	67,0	66,2	58,4	-	-	73,4	72,9	71,0	68,6	67,0	77,0	76,2	75,2	74,0	72,7	
	KW	0,9	1,4	2,5	-	-	1,0	1,5	3	4,5	5,7	1,2	2	3,8	5,6	7,4	
GR45	180 L	l/min	81,5	80,4	74,0	-	-	88,6	88,0	85,7	83,4	81,2	92,9	92,0	90,8	89,3	87,9
		KW	1,2	1,8	3,4	-	-	1,5	1,8	3,5	5,4	6,7	1,5	2,4	4,6	6,8	8,9
210 L	l/min	96,2	95,2	86,0	-	-	103,0	102,0	99,0	96,2	94,3	108,0	107,2	105,6	103,8	101,9	
	KW	1,4	2	3,8	-	-	1,6	2,2	4,0	6,0	7,8	1,6	2,7	5,4	7,9	10,4	
GR55	250 L	l/min	126,6	125,5	115,0	-	-	135,0	134,0	131,6	129,0	126,2	139,0	138,5	137,3	135,9	134,0
		KW	1,6	2,7	5,0	-	-	2,0	3,0	5,3	8,0	10,5	1,9	3,5	6,9	10,5	13,5
	300 L	l/min	141,0	140,0	128,4	-	-	150,0	149,0	146,6	143,5	140,0	154,0	153,2	152,0	150,4	148,0
		KW	1,8	3,0	5,5	-	-	2,2	3,5	6,0	9,0	11,6	2,2	4	7,7	11,4	15
330 L	l/min	160,0	158,7	146,0	-	-	170,0	168,8	166,0	162,5	160,5	175,0	174,0	172,2	170,0	168,0	
	KW	2,0	3,5	6,0	-	-	2,5	4,0	6,8	10	13	2,5	4,4	8,7	13	17	
380 L	l/min	179,0	176,7	161,0	-	-	189,5	188,0	185,0	182,0	179,0	196,0	195,0	192,8	190,5	188,0	
	KW	2,6	4,0	7,0	-	-	3,0	4,5	7,6	11	14,6	2,6	5	9,7	14,6	19	
GR 60	440 L	l/min	208,0	206,0	198,0	-	-	221,0	219,0	217,0	214,0	211,0	229,5	228,5	226,0	223,0	220,0
		KW	2,8	4,5	8,2	-	-	3,2	5,0	9,0	13,0	17,4	3,0	5,9	11,5	17,0	22,0
500 L	l/min	239,0	236,0	227,0	-	-	252,0	250,0	247,0	244,0	241,0	260,0	259,0	256,0	253,0	250,0	
	KW	3,2	5,0	10,0	-	-	3,3	5,5	10,0	15,0	20,0	3,5	6,6	13,0	19,0	25,0	
GR 70	600 L	l/min	290,0	287,0	275,0	-	-	306,0	304,0	300,0	297,0	294,0	315,0	313,0	310,0	306,0	303,0
		KW	3,6	6,0	11,0	-	-	4,0	6,5	12,5	18,0	24,0	4,3	8,0	15,8	23,0	30,0
	660 L	l/min	316,0	314,0	301,0	-	-	335,0	332,0	328,0	325,0	321,0	343,0	341,0	337,0	332,5	328,0
		KW	4,0	6,8	12,0	-	-	4,5	7,0	13,5	20,0	26,0	4,7	8,7	17,0	25	33,0
800 L	l/min	381,0	378,0	365,0	-	-	406,0	403,0	399,0	396,0	390,5	415,0	413,0	409,6	405	401,0	
	KW	4,5	8,0	15,0	-	-	5,5	9,0	16,0	24,0	31	5,8	10,5	20,5	31	40,0	
GR 80	1.000 L	l/min	483,0	480,0	462,0	-	-	509,0	506,0	501,0	496,0	490,2	516,0	514,0	511,0	507	502,0
		KW	6,0	10,0	19,0	-	-	6,0	10,0	21,0	30,0	40	7,0	13,0	26	38	50,0
1.200 L	l/min	586,0	582,0	562,0	-	-	615,0	612,0	606,0	600,0	594,0	627,0	625,0	621,0	615	610,0	
	KW	7,0	12,0	23,0	-	-	7,5	13,0	25,0	36,0	48	9,0	16,0	31	46,0	61,0	

(*) For high viscosity applications and/or oil-air emulsions, please check with us the suitable pump model

The data shown in the catalogue can change without notice.
For special applications – please contact the main office.

Ordering code

GR **	****	***L	*	****/***	*	*	***	***	
1	2	3	4	5/6	7	8	9	10	
Pump Type	Dry or submersible	Nominal Flow (L/min 2750 rpm)	High viscosity flag ⁽¹⁾	Hollow shaft type / Flange type (Omit for normal shaft)	Pump body	Shaft Seal	Internal pressure relief valve ⁽²⁾	Rotation	
GR20		8							
		12							
		15							
		23							
GR25		25					None		
		30	None	Motor shaft (5)			No security valve		
GR32		35	Up to 100 cSt						
		45							
		55					None	RF1	
		75	S1		AC11	None	NBR	5 bar security	
GR40	SMT16B dry	100	from 100 to 250 cSt	AC14	Aluminium	V		None	
		125		AC19		Viton	RF2	Right rotation	
		150	S2	AC24	G		10 bar security		
GR45	SMT16B submersible	180	from 250 to 500 cSt	AC28	Cast iron	E		REV ⁽³⁾	
		210				EDPM		Reversible rotation	
GR55		250		Motor form (6)	A		RF3		
		300	S3		Carbon steel (18NiCrMo5)	F	15 bar security		
		330	from 500 to 800 cSt	B5		FPM			
		380		B14					
GR60		440	S4				RP ⁽²⁾		
		500	past 800 cSt	B5R			Variable regulation valve		
GR70		600							
		660							
		800							
GR80		1.000							
		1.200							

- (1) this option reduce the efficiency of the pump
 (2) RP valve available only for GR32, GR40 and GR55 models
 (3) REV available only for GR32 and GR40 models

Example:

1) GR55 SMT16B 250L S2 AC28/B5 G V RF1

Pump providing a nominal flow of 250L, for thick oil (operation viscosity between 250 and 500 cSt), hollow shaft diameter 28 (motor 132) flange B5, cast iron body, Viton seals, pressure relief valve at 5bar – DO NOT NEED bell-housing and coupling, mountable directly on the motor

2) GR80 SMT16B 1.000L

Pump providing a nominal flow of 1.000 L/min at 2.750 rpm, normal shaft, aluminium body – need bell housing and coupling

The data shown in the catalogue can change without notice.
 For special applications – please contact the main office.

Main Office:

Area Agency/Reseller:

SETTIMA MECCANICA s.n.c.

29020 Loc. Conca di Settima – Gossolengo (PC) – Italy

Tel: +39 0523 557623 – Fax: +39 0523 557256

www.settima.it – info@settima.it



SETTIMA MECCANICA